

SUPPLIER TO MARK HIS LOGO AND SR.NO ON THE ROLL

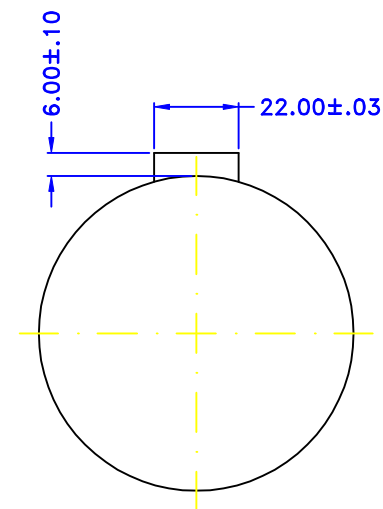

KEYWAY DETAILS

GROOVE PROFILES

- A) STATION NO. 1-8 ACCORDING TO DRG. NO 1R10C.
- B) STATION NO. 9 ACCORDING TO DRG. NO 1R10B.
- C) STATION NO. 10 ACCORDING TO DRG. NO 1R10D.

PROVIDE +0.5mm ALLOWANCE FOR EACH GROOVE PROFILE FOR FINAL GRINDING AT OUR END.

- MATERIAL : WORKSTOFF NO 1.2601 / DIN X 165 Cr Mo V 12 / ASSAB XW41 OR 42 ⚠
- REQD.HARDNESS : 56-58 HRC (THRU' HARDENED)
- \* DIMENSIONS IN BRACKET ARE PRIOR TO HEAT TREATMENT : VACUUM TREATMENT ⚠ SUBZERO TREATMENT
- ALL DIA AND GROOVE PROFILE TO BE CONCENTRIC WITHIN 0.025mm ⚠
- GROOVE FINISH 0.4 μm ALL OVER GROOVE SURFACE ⚠
- ST.CODE : RM1-1703-001 TO RM1-1703-010

METROD (MALAYSIA) BERHAD

				METROD (MALAYSIA) BERHAD					
				DESCRIPTION		ROLL			
ALL DIMENSIONS ARE IN MM UNLESS OTHERWISE SPECIFIED.	3	04.02.98	ADDED NOTES	DATE	29.09.94	SCALE	~	DRAWING NO.	REV
	2	29.09.94	NEW DRAWING	DRN.BY	FAZIDAH	APP.BY		1R10A	3
	S.NO	DATE	REVISION NOTE	APP.					